

A ( 1 : 10 )

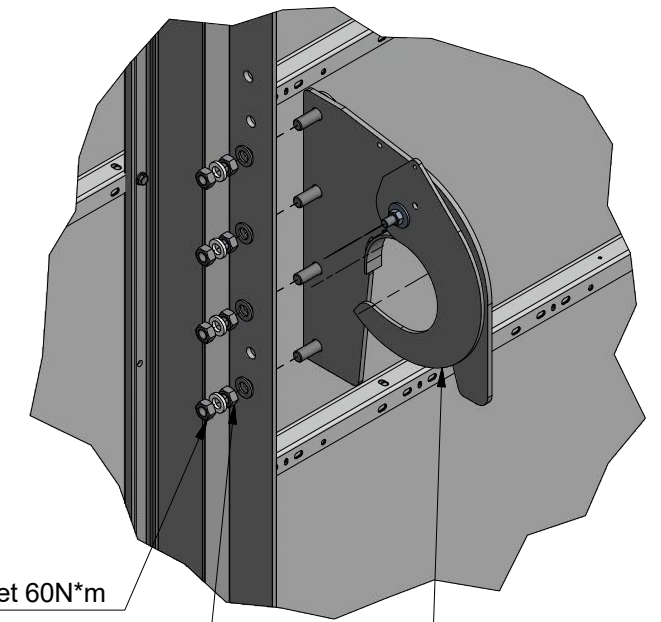

2de Moer 60N\*m

1ste Moer 170N\*m

Bij paneelborden kleiner als 9 m worden de buitenstelaanders voorzien van een ophangoor met sluihaak

Bij borden groter als 9 m moet ook de middelste staander worden voorzien van ophangoor met sluihaak

B ( 1 : 10 )

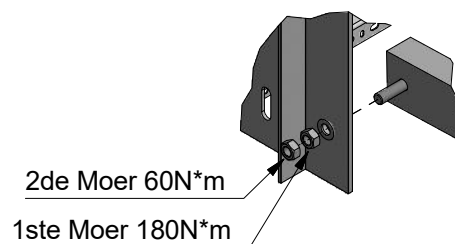

2de Moer 60N\*m

1ste Moer 180N\*m

C ( 1 : 10 )

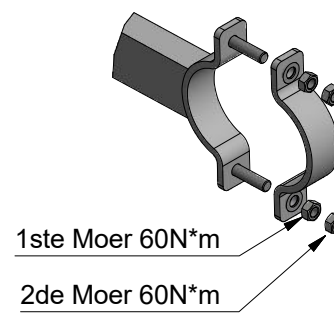

1ste Moer 60N\*m

2de Moer 60N\*m

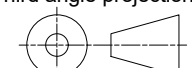
		Material:	Mass: N/A
		Doc no.: 20210629HAKA01-01.dwg	
Third angle projection:		Part number:	
		Description: Paneelbord .....x..... mm.	
Drawn by: HAKA	Creation date: 30-6-2021	Revision:	
Checked by:	Checked date:	Format: A3	
Scale 1 : 20	Units: mm		
Status: WorkInProgress			
Agmi Group, Steenweg 11B / 5932 AC Tegelen , tel: +31 773739100, www.agmi.nl, info@agmi.nl			