

Let op!!!

Borden met een tweede borddeel hoger als 2400mm worden van een dubbele koppelplaat voorzien.
Achtergrondschild krijgt 1 koppel plaat per staander.

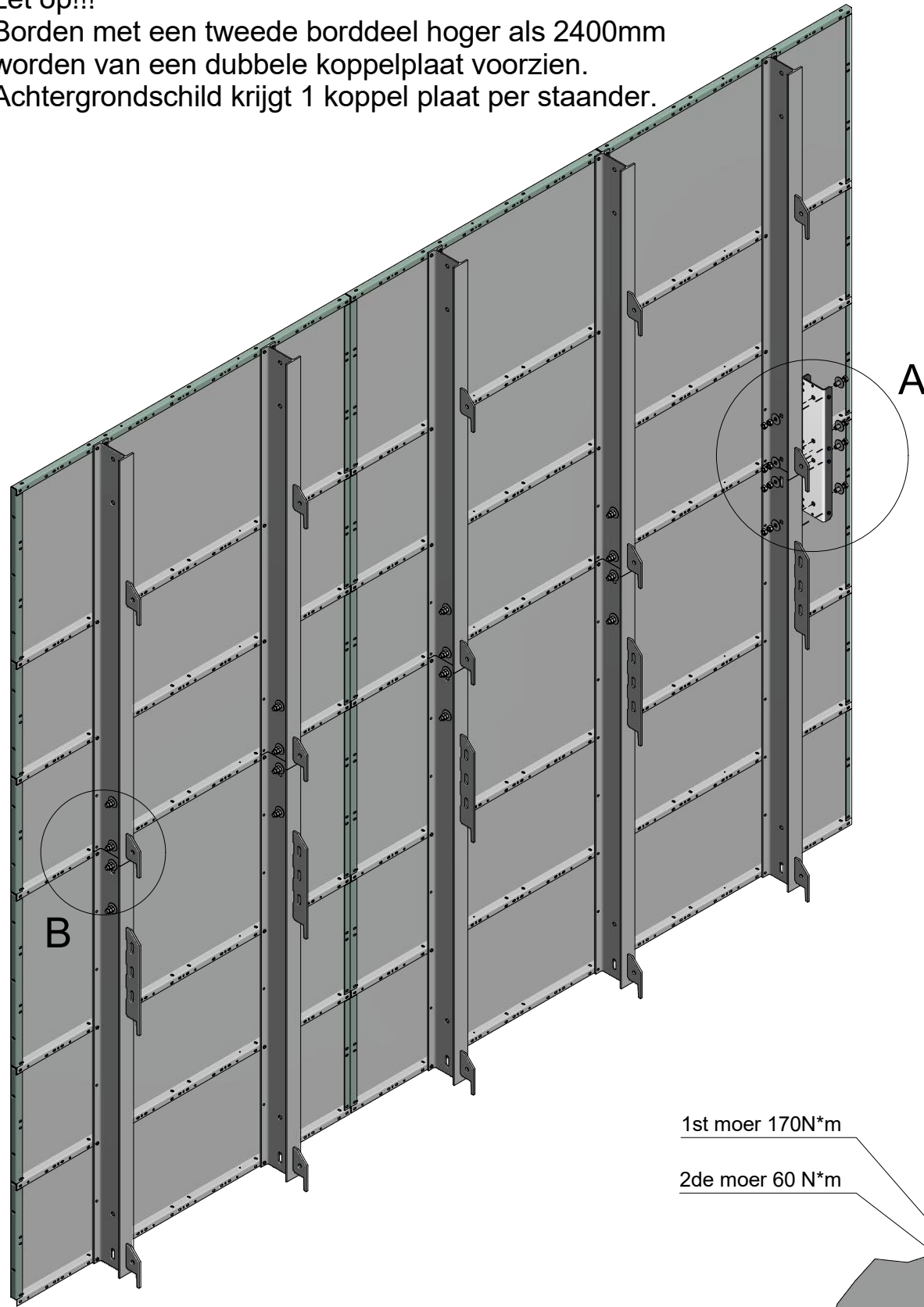

1st moer 170N*m
2de moer 60 N*m

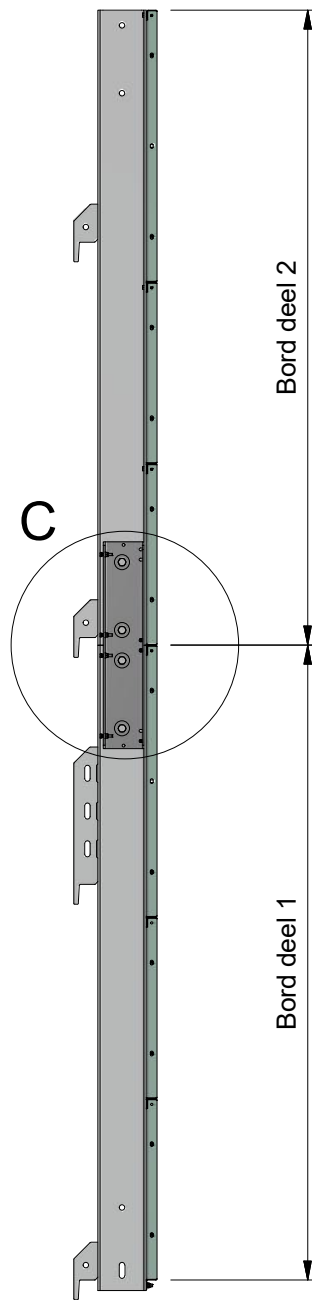
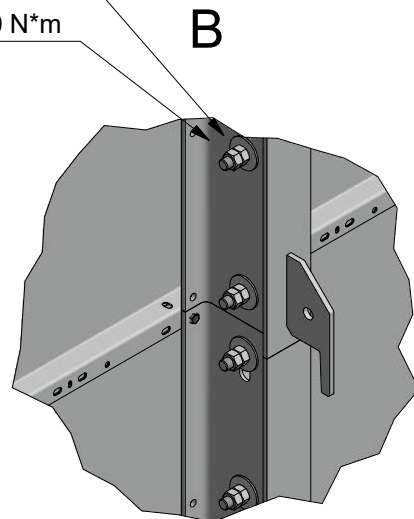

D9021 THVZ CARROSSERIERING M16

D934 TH/ISO ZESKANTMOER M16

D934 TH/ISO ZESKANTMOER M16

A

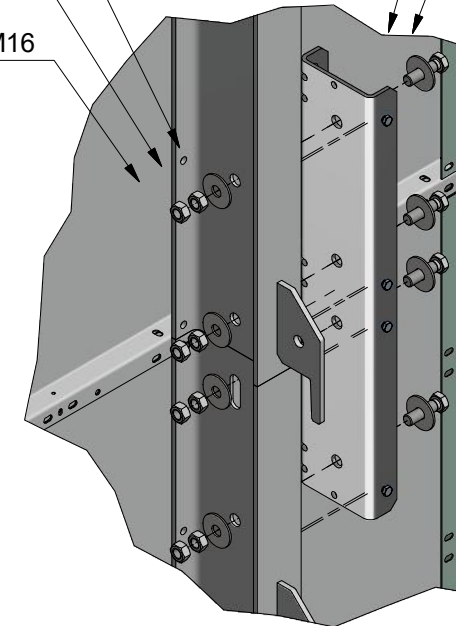

D9021 THVZ CARROSSERIERING M16

D933 TH/ISO ZESKANTTAPBOUT M16x70mm KL8.8

Aandraaimoment 30N*m

C

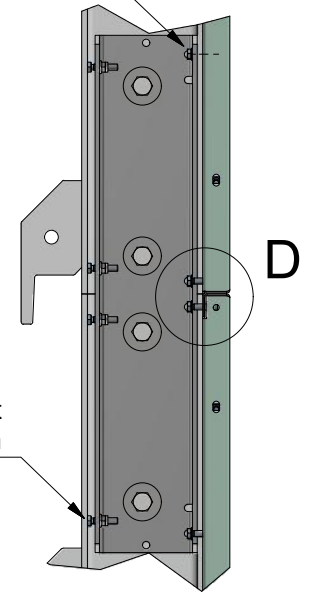

D

DIN 125-1A SLUITRING M8 RVS A2

DIN 6926 Flensmoer M8 RVS-304

D

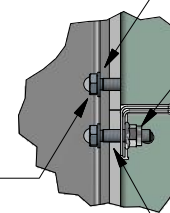

Bout/moer verbinding mag ook andersom gemonteerd worden

Bout tegen binnenkant balk klem aandraaien

DIN 933 TAPBOUT M8X35 RVS A2

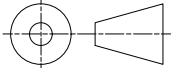
		Material:	Mass:	N/A
		Doc no.: 20211123HAKA03-01.dwg		
Third angle projection:		Part number:		
				
Drawn by: HAKA	Creation date: 23-11-2021	Description: Montagevoorschrift Koppelset Paneelborden met IPE160 standers		Revision: A
Checked by:	Checked date:			Format: A3
Scale 1 : 25	Units: mm			
Status: WorkInProgress				